

Metastable microheterogeneity of melts in the Ga–Bi system with limited solubility of components in liquid state

D. Yagodin · P. Popel · V. Filippov

Received: 6 June 2009 / Accepted: 8 January 2010 / Published online: 26 January 2010
© Springer Science+Business Media, LLC 2010

Abstract A set of acoustic (using the pulse phase method for ultrasound velocity v_s measurement) and γ -absorption experiments with the Ga–Bi melts have been performed to clear the nature of their microinhomogeneity. Both methods allow determining v_s and intensity of the penetrating γ -beam, I , at various distances, h , from the bottom of the measuring cell. Distinct $v_s(h)$ and $I(h)$ dependences were discovered in one phase domain of the phase diagrams. It is clear that such inhomogeneity is connected with the chemical inhomogeneity of the melt which, in its turn, can exist if one of the components forms very large particles containing 10^4 – 10^5 atoms. The cupola-like borders of the domains where such inhomogeneity exists were fitted in the phase diagrams of the systems under investigation. The inhomogeneity has been confirmed in special acoustic experiments with superposition of ultrasound and low-frequency oscillation.

Introduction

Signs of isolation of microsegregations of atoms belonging to one kind are found in systems with immiscibility cupola in the domain of one-phase state of melts. Diffraction curves of such melts can be presented as a result of a superposition of the diffraction patterns of pure components [1]. Various anomalies (in particular, viscosity and electrical resistance maxima [2]) are recorded on the isotherms of

properties at temperatures slightly above the critical demixing temperature T_c , close to critical concentration. The appearance of the above-mentioned microsegregations in such systems is connected with the predominant interaction of similar atoms and near the critical point can go by way of fluctuations. But as the distance from it increases the rate of fluctuations should sharply decrease. Indeed, the maxima on the electrical resistance isotherms disappear as the temperature is raised by only 2–3 K above T_c . At the same time, viscosity anomalies, which are the evidence of large-scale microinhomogeneity of the melts, are registered also at overheating by dozens and even hundreds degrees above the critical point [3].

The theory of metastable microheterogeneity of liquid metal solutions [4] allows explaining the microinhomogeneity of monotectic melts far from the critical point. Indeed, as the temperature of such a system is increased starting from its solid state, a macroscopically inhomogeneous melt with a distinct interface between two immiscible liquids is firstly formed. At further heating and transition through cupola of segregation the system should pass into the true solution state. However, due to the initial heterogeneity one of the phases first disperses in the other to nanometric size and the resulting drops of the dispersed phase persist in the melt for a long time, forming a metastable microemulsion.

Earlier in [5] a pronounced inhomogeneity of ultrasound velocity, v_s , was found in Ga–Pb melts containing from 20 to 80 at.% Pb along the vertical coordinate h outside the domain of their macroscopic segregation. With the increase of temperature, the inhomogeneity of ultrasound velocity decreased sharply and, starting from a certain temperature T_h the values v_s became independent of h . At cooling of the melts heated over T_h the ultrasound velocity v_s remained homogeneous up to the temperature of segregation T_s . The

D. Yagodin · P. Popel (✉)
Ural State Pedagogical University, 26 Cosmonavtov ave.,
Ekaterinburg 620017, Russia
e-mail: pspopel@mail.ru

V. Filippov
Ekaterinburg Higher Artillery Command School,
145 Tscherbakova st., Ekaterinburg 620108, Russia

authors connected this effect with the prolonged existence of Ga–Pb melts in metastable microheterogeneous states.

The results of acoustic and densitometric experiments with Ga–Bi melts confirming these ideas are presented in this work.

Experimental

Procedure of ultrasound velocity measurement

Pulse phase method for ultrasound velocity measurement based on direct measurement of its wave length λ and frequency f was used in the work. Sound propagation velocity in this case is determined from the relationship

$$v_s = \lambda f. \quad (1)$$

The method does not require any prior calibrations, and, therefore, is absolute. The description of the experimental assembly realizing the method is given in Fig. 1. In this diagram, two generators—pulse (1) and high-frequency sinusoidal (2)—form a rectangular electrical pulse of high-frequency oscillations ($f = 31.33$ MHz). Piezoelectric elements transform this pulse into an acoustic one. It passes

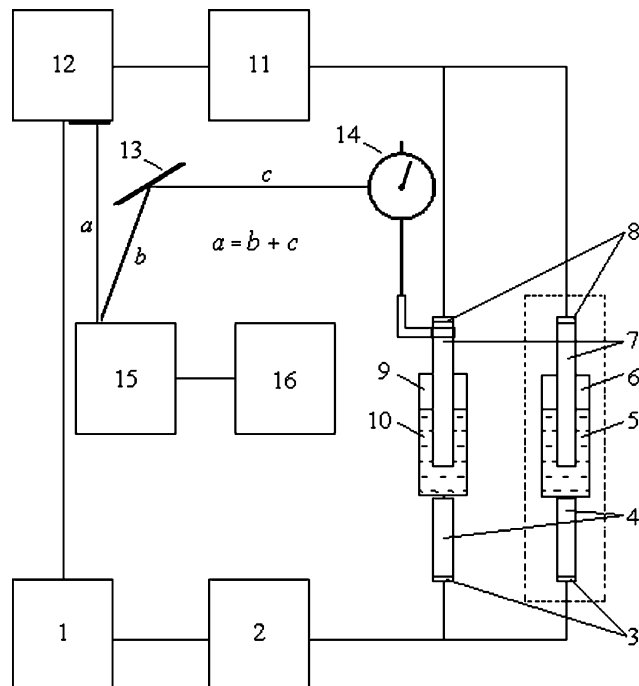

Fig. 1 Block diagram of the assembly for ultrasound velocity measurement in melts. 1 pulsed signals generator, 2 sinusoidal signals generator, 3 and 8 piezoelectric elements, 4 and 7 acoustic lines, 5 index liquid, 6 container for index liquid, 9 container for the investigated sample, 10 investigated sample, 11 selective amplifier, 12 oscillograph, 13 mirror, 14 indicator micrometer, 15 video camera, 16 computer

through two identical acoustic cells. One of them (6) contains the liquid under investigation (5), and the other (comparison cell) (10) is filled with distilled water (9). At the outlet, the ultrasonic pulses are again transformed into electrical ones by piezoelectric elements (8). Since the delay time of the cells is selected to be almost identical, the electric signals transmitted along the circuit interfere and the result of their interference after the amplification in (11) is observed on the screen of the oscillograph (12). The upper waveguide in the measuring cell can move along the vertical axis. This movement can be measured by a micrometer (14). When the waveguide moves, a succession of extrema of interference signal is observed on the screen of the oscillograph. The distance between the two nearest minima or maxima is equal to the length of the ultrasonic wave, λ .

To raise the precision of measurement to an acceptable value, the shift of the upper waveguide Δh is measured, which corresponds to the appearance of n consecutive minima. The wave length is then calculated according to the formula

$$\lambda = \Delta h/n, \quad (2)$$

and the ultrasound velocity

$$v_s = (\Delta h/n)f \quad (3)$$

this value corresponds to the mean value of ultrasound velocity in the layer of the liquid under investigation with thickness Δh adjacent to the end of the upper waveguide. It is the possibility of measuring practically all the local values of ultrasound velocity in various parts of the melt that is a unique distinguishing feature of the pulse phase method.

The authors have suggested and implemented an original method of recording the video image of interference pattern observed on the screen of the oscillograph. It allows getting full information about the distribution of the coordinates of interference minimum along the height of the liquid sample, that is, to determine the dependence of sound velocity on the vertical coordinate. The concept of the method is clear from the block diagram on Fig. 1. The image of the indicator micrometer (14), which is used to measure the vertical shifts of the upper (movable) waveguide (7), is projected onto the focal plane of a digital video camera (15) with the help of a mirror (13). Right in front of the camera there is a screen of a high-frequency oscillograph (12), at the same distance $a = b + c$ as the micrometer. Therefore, the experimenter does not need to record the coordinates of the minima during the experiment; this is done by the video camera connected to the computer (16). The image from the screen of the oscillograph and the mirror image from the indicator micrometer are stored in the video format on the computer. For a

sample 25 mm in height, a full video fragment can be obtained during only 10–15 min, while recording the positions of the minima “by hand” takes about 2 h. The precision of measurement in the new method of recording is in no way inferior to the precision of the traditional technique. Its additional advantages are recording all the coordinates of interference minima found along the height of the sample, that is, getting the fullest possible dependence $v_s(h)$, storing the experimental information in the memory of the computer and the possibility of processing it at any time after the experiment and with any required precision.

The total relative error of determining the propagation velocity of ultrasound using this method does not exceed 0.2%.

Procedure of determining density inhomogeneity along the height of the sample

Densitometric measurements using penetrating γ -radiation are based on the well-known formula of γ -quanta flux attenuation by a sample of d density

$$I = I_0 B \exp(-\mu dl) \quad (4)$$

where I_0 , I are the beam intensities before and after the absorber (the sample), respectively, l is the γ -quanta path length in the sample, μ is the mass attenuation factor that depends on the chemical composition of the sample and the γ -quanta energy, B is the build-up factor that takes into account the amount of γ -quanta remaining in the beam of finite width after interacting with the atoms of the absorber. Thus, by measuring the intensity of the γ -quanta beam going through a cylindrical sample in diameter at various distances from the top to the bottom of the crucible we can judge about the inhomogeneity of the density of the melt along the vertical line.

The block diagram of the γ densitometer is given in Fig. 2.

The isotope ^{137}Cs of initial activity 1 Ci is the source of γ radiation (1) in it. The intensity of the γ -quanta beam passing through the diameter of the cylinder beryllium oxide crucible with the sample (2) is measured by a scintillation detector (3) with a NaJTe monocrystal. The pulses from the detector come to the input of the radiometer (4), which performs their formation, amplitude discrimination, and counting with the subsequent transfer of the information onto a digital printer (5). The temperature of the sample is determined by one of the tungsten–rhenium thermocouples (6), which is immersed into the sample in a protective cover in close proximity to the radiographed zone. The thermal electromotive force of the thermocouple is measured by a digital voltmeter (7), which is also connected to the digital printer. This thermocouple can also be

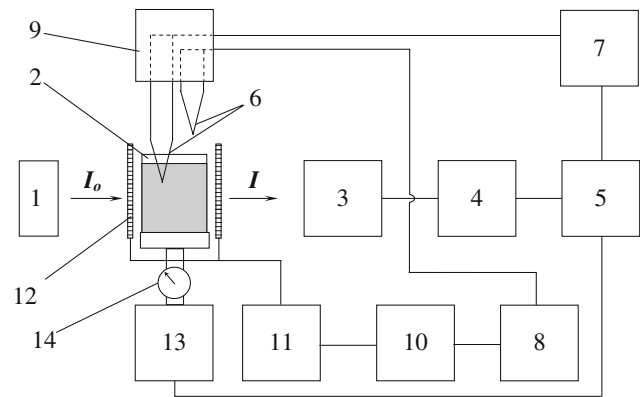

Fig. 2 Block diagram of γ densitometer. 1 the source of γ -quanta, 2 crucible with the sample, 3 scintillation detector, 4 radiometer, 5 printer, 6 thermocouples, 7 voltmeter, 8 thermoregulator, 9 thermostat, 10 thyristor unit, 11 power transformer, 12 tantalum heater, 13 device for controlled vertical movement of the crucible, 14 indicator micrometer

used in the construction under discussion as a rather effective stirring device for stirring the melt mechanically at any stage of the experiment.

The second thermocouple (6) is above the sample. This is a feedback sensor which is used to select the temperature regimes of the assembly operation. These regimes are controlled by a precision program temperature regulator (8). The cold ends of both thermocouples are in the thermostat (9). The temperature regulator controls the voltage on the transformer (10) through the thyristor power unit (10), allowing heating the sample continuously or discretely by means of the tantalum heater (12). The original device (13) designed by D. Jagodin allows moving the sample vertically about the axis of the γ -quanta beam. This movement is controlled visually by the indicator micrometer (14).

Density measurement within various distances from the bottom of the crucible considerably expands the performance capabilities of the experimental assembly. In particular, it allows studying density distribution in the systems with layering and locating the position of the meniscus, and also it allows studying the effects of sedimentation of disperse particles in a micro-heterogeneous melt.

The statistical error of measuring the intensity of γ -quanta flux passing through the crucible with melt is between 0.12 for Ga and 0.25% for Bi.

Experimental results

After mixing the components, the samples in our experiments with Ga–Bi alloys were heated at the rate of 25, 50, or 100 K/h up to the temperature lying above the cupola of

macroscopic segregation of the system. Then, after establishing an acoustic contact between the waveguides, the system was heated during approximately 90 min by 50 K more and during the following 30 min the dependence $v_s(h)$ at this temperature was recorded. The measuring process was repeated at further heating until reaching the temperature at which within the limit of measurement accuracy the ultrasound velocity stopped depending on the vertical coordinate.

The results are presented in Figs. 3 and 4. As in the experiments [5] with Ga–Pb melts in monophasic states, domain a pronounced dependence of ultrasound velocity on the vertical coordinate is found on the phase diagram of the system, which exists at least during several hours and is preserved at overheating by 200–400 K above the cupola of segregation. With the increase of temperature, the inhomogeneity v_s decreases and, starting from a certain temperature T_h the ultrasound velocity becomes constant along the whole sample. At cooling of the melt heated over T_h , the ultrasound velocity, v_s , remains constant along the vertical axis h down to the temperature of segregation T_s .

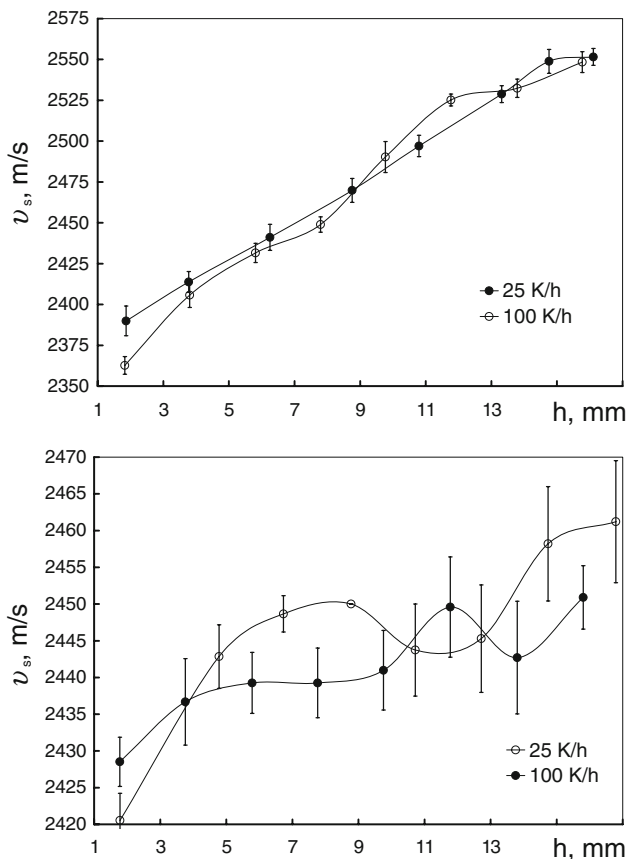

Fig. 3 Dependences of ultrasound velocity in Ga–11 at.% Bi melt on the distance from the bottom of the crucible at 723 K (above) and at 873 K (below), received: filled circle after melting the mixture of the initial components, open circle after melting the crystalline two-phase ingot

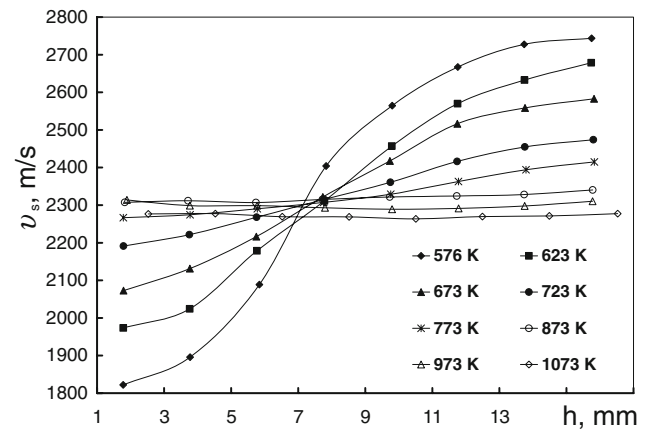

Fig. 4 Dependences of ultrasound velocity on the distance from the bottom of the crucible for Ga–17 at.% Bi melt obtained at heating rate 50 K/h

At further decreasing the temperature, the dependence $v_s(h)$ appears again, which indicates the start of the macroscopic segregation of the sample.

If the melt is cooled up to the temperature lying slightly below T_s , is kept at this temperature for about 30 min and is again heated over the cupola of macroscopic segregation, the inhomogeneity of ultrasound velocity persists for a long time. The dependences $v_s(h)$ registered in this case depend on the depth of penetrating into the area of layering and are not so distinct as in the case of heating the initial components (Fig. 3). After the crystallization of the melt and its second heating above the cupola of macroscopic segregation, the dependences of ultrasound velocity v_s on the vertical coordinate are registered, which coincide with the similar curves presented in Fig. 3. The experiments have shown that the change of the form of the curve $v_s(h)$ with the temperature does not depend on the way in which the mixing of the sample was done: by mixing pure components or by adding one of them to the prepared pseudoalloy. The comparison of results received at various rates of heating the Ga–11 at.% Bi melt (Figs. 3, 4) shows that over the investigated range of rates the inhomogeneity v_s practically does not depend on the heating rate.

For a number of Ga–Bi alloys, height homogeneity was studied by γ densitometry method. The dependence of the intensity of γ -quanta flux I , going through the sample in diameter on the distance from the beam to the bottom of the crucible h was studied using the scanning attachment to the γ densitometer described in part 2, in the same temperature and time conditions that were applied in acoustic measurements. The obtained results are presented in Fig. 5. Density inhomogeneity along the height of the samples of Ga–Bi melts, first mentioned in [6], was revealed in these measurements. It shows a considerable enrichment of its lower part with a heavy component (in our case—bismuth). The

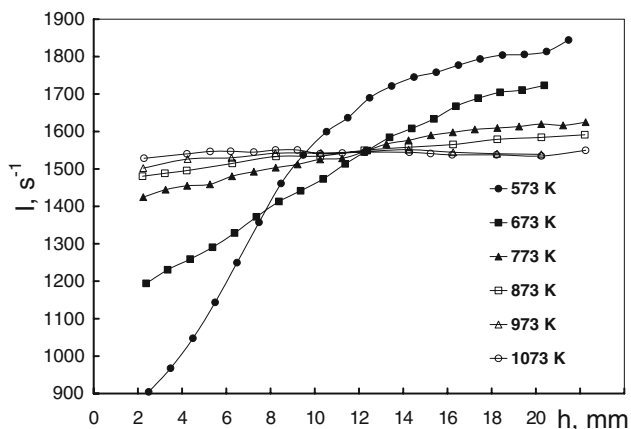

Fig. 5 Dependencies of intensity of γ -quanta flux I , penetrating the sample in diameter on the distance from the beam to the bottom of the crucible h for Ga–17 at.% Bi melt obtained at heating rate 50 K/h

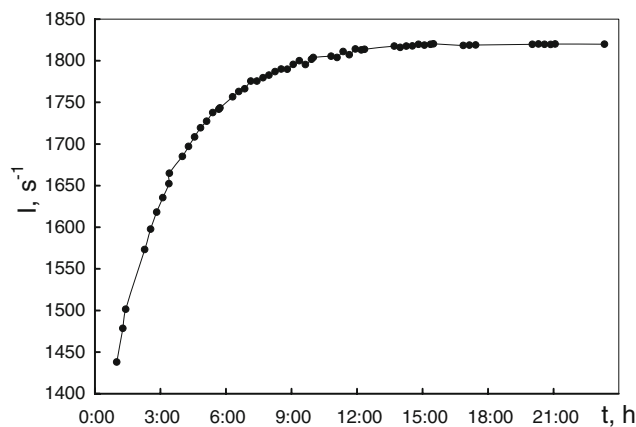

Fig. 6 Dependence of intensity of γ -quanta flux I , penetrating the sample Ga–11 at.% Bi in diameter near the bottom of the crucible at 973 K

duration and temperature interval of the existence of this inhomogeneity are close to the corresponding characteristics of the above mentioned inhomogeneity of ultrasound velocity, which allows assuming that they are similar in nature. The dependence of the passing beam intensity on the vertical coordinate disappears at approximately the same temperatures T_h that were obtained during acoustic experiments with the melts of the corresponding concentrations.

In a special series of experiments, we performed a fast heating of the mixture of the initial components to various temperatures lying above the cupola of macroscopic segregation and a consecutive measurement of the dependence of ultrasound velocity on the distance from the bottom of the crucible in isothermal conditions until these dependencies disappeared completely. It was found that at temperatures considerably above T_h point of the disappearance of the dependencies $v_s(h)$ in Figs. 3 and 4, the homogeneity of the system along its height takes less than 40 min to set in. Near T_h , relaxation time goes up to several hours. At temperatures lying below T_h , the relaxation of the mixture of initial components is practically unremarkable that its characteristic time of the melt inhomogeneity existence can be only approximately estimated as about several dozen hours.

The intensities of γ -quanta flux I , going through the sample in diameter near the bottom of the crucible were sequentially measured for an alloy containing 11 at.% Bi, after heating the mixture of the initial components to 673 K or 973 K during a long period of time. Despite the fact that the experiments lasted for more than 24 h, no distinct change in the intensity was found at the first temperature. At 973 K, the dependencies $v_s(h)$ and $I(h)$ in Figs. 3, 4, and 5 were not revealed any more, and the changes in the intensity of the passing beam with time were recorded during 14 h (Fig. 6).

A considerable inhomogeneity of ultrasound velocity along the height of the melt, in our opinion, indicates its microheterogeneity, i.e., the existence of disperse particles in the melt, which are enriched with one of the components and separated from the environment by a sharp interface.

It should be also noted that when the melt which is starting to separate into layers macroscopically is heated above the binodal (cupola of segregation) over a rather long temperature interval (about 200 K) there are no signs that the curve approaches the corresponding dependence received at the cooling of a homogeneous sample. It confirms the hypothesis stated in [5] about the metastability of microheterogeneous state in this temperature interval. Evidently, if the temperature is increased further, the process of its destruction begins, which finishes near the branching point of the curves $I(T)$.

After [5], the authors connect the observed density and ultrasound velocity inhomogeneity in Ga–Bi melts above the cupola of their macroscopic segregation with the formation of a metastable or nonequilibrium colloid microheterogeneity in them. Apparently, after the transition of the system into the domain of the phase diagram corresponding to monophasic states, a microemulsion persisting for a long time is formed by disperse particles of one of the components, which are suspended in the dispersion medium enriched with the other one. The absence of any noticeable signs of relaxation of the melts at their slight overheating above the point of segregation allows suggesting a hypothesis of the metastability of the colloid state of the melt in this range of compositions and temperatures. Apparently, near the temperatures T_h corresponding to the disappearance of the dependencies $v_s(h)$ and $I(h)$ in Figs. 3 and 5 the microheterogeneous state becomes nonequilibrium and its relaxation time decreased rather fast at the further increase of temperature.

To check this hypothesis, we used the method of detecting colloid particles in microheterogeneous melts offered by Filippov [5]. The essence of the method is observing the changes in the amplitude of ultrasound signal passing through the melt, where low-frequency mechanical oscillations were excited as a result of the back-and-forth motion of the upper acoustic guide. The essence of the method is observing the change in the amplitude of ultrasound signal passing through the melt, in which low-frequency mechanical oscillations were excited as a result of reciprocal motion of the upper acoustic guide. The pattern of these oscillations is presented in Fig. 7; their frequency was 1–2 Hz at the amplitude of about 0.2 mm. When in such motion, the melt moves upwards from a lower level in the center of the crucible to its side and back. In the author's view, when microscopic drops with a sharp interface exist in the system, there is a scattering of ultrasound waves at this interface, which is accompanied by a noticeable attenuation of the passing signal. When low-frequency mechanical oscillations of the melt are excited, the concentration of disperse particles on the ultrasound signal propagation path varies with time. This leads to the variation of the ultrasound signal amplitude.

During the experiments with Ga–Bi melts after their heating above the macroscopic segregation point, T_s , and exciting low-frequency oscillations, as in the experiments [5] with Ga–Pb melts, pulsations of ultrasound signal were really observed, which is a sign of the presence of a great number of scattering centers. The amplitude of the pulsations increases with the approaching of the melt composition to a critical one and decreases with the increase of temperature. At overheating the melt by approximately

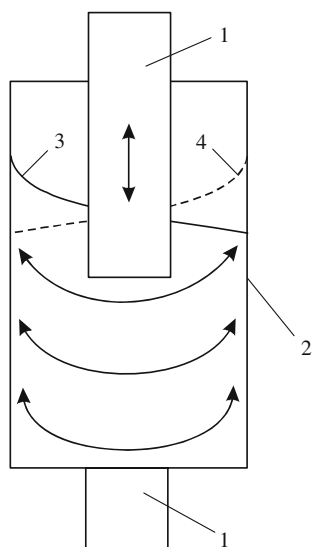

Fig. 7 Diagram of melt oscillations in the crucible. 1 acoustic line, 2 crucible with melt, 3, 4 position of meniscus. Arrows show the movement of the melt

100–150 K above T_s the variations disappear. At cooling the melt, heated over T_h at which the dependences $v_s(h)$ and $I(h)$ disappear in Figs. 3 and 5, no variations of ultrasound signal amplitude were found.

Therefore, the conducted experiments confirmed our idea concerning the formation of metastable or nonequilibrium microheterogeneity of Ga–Bi melts after their heating above the cupola of macroscopic segregation and concerning its irreversible destruction near the temperature T_h . Therefore T_h can be really considered as the temperature of irreversible homogenizing of the melt.

The value T_h for Ga–17 at.% Bi melt turned out to be 960 ± 20 K. The value of temperature of homogenizing is reproduced with the stated accuracy at consecutive measurements with the samples of identical composition and when the rate of heating is varied. According to the results of γ -densitometry of the same melt, $T_h = 970 \pm 20$ K. Consequently, the presented techniques yield the values of T_h that are in good agreement with each other. For the melt containing 11 at.% Bi the value of T_h from acoustic measurements is 910 ± 20 K.

In the cases when the Ga–11 at.% Bi melt inhomogeneity was created by subcooling the homogenized melt below the temperature of its macroscopic segregation, its homogenizing temperature practically did not depend on the degree of its initial supercooling and was 850 ± 30 K at the heating rate 50 K/h and 870 ± 30 K at 100 K/h in monophasic domain.

According to the results of the study of melts obtained at heating the mixture of initial components, crystalline bimetallic samples, and the samples subjected to isothermal soaking in the phase separation area, a boundary of the region of the metastable microheterogeneity existence is built on the phase diagram of the Ga–Bi system (Fig. 8). It looks like a cupola-like curve $T_h(x)$. The data concerning T_h which correspond to the various ways of preparing the melts are in good agreement with each other. The emulsion received at heating the mixture of the initial components or melts subjected to isothermal soaking in a two-phase domain is nonequilibrium above the curve of macroscopic segregation and passes into a metastable state at thermal treatment or stirring the melt below T_h . Above T_h , the disperse system is unstable and passes into a homogeneous state. Homogenizing temperature is maximal when the concentration of bismuth is about 25 at.%, where it exceeds the critical segregation temperature by approximately 440 K.

The effectiveness of mechanical stirring for homogenizing the melt was studied in some experiments. In particular, at 573 K ($T > T_s$) the Ga–51.55 at.% Bi melt was mixed with gallium up to the calculated composition Ga–41.96 at.% Bi, and the dependence of the intensity, I , of γ -quanta beam penetrating through the sample on the

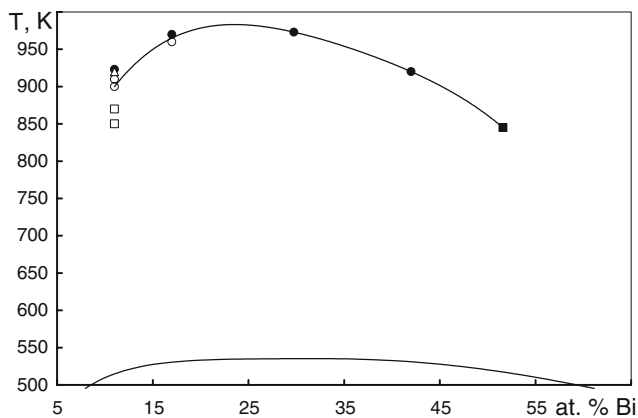

Fig. 8 Boundary of the domain of the metastable microheterogeneity existence on the diagram of Ga–Bi system state built from the results of acoustic (*open symbols*) and γ -densitometric (*closed symbols*) experiments with melts prepared at heating: *closed circle, open circle* the mixture of initial components, *open triangle* crystalline bimetallic ingot, *filled square, open square* melts subjected to isothermal soaking the region of segregation

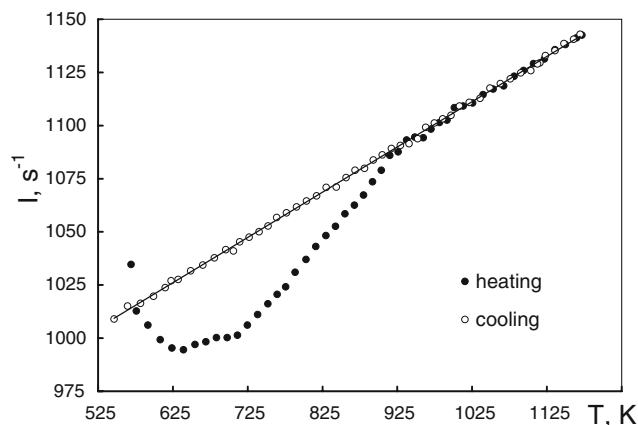

Fig. 9 Temperature dependences of intensity of γ -quanta flux I_s penetrating the Ga–41.96 at.% Bi melt in diameter near the bottom of the crucible after admixing the necessary amount of gallium to the sample containing 51.55 at.% Bi and mechanical stirring done twice at 573 K; rate of temperature change at heating and subsequent cooling 50 K/h

distance of the beam from the bottom of the crucible was measured. When the beam passes near the bottom of the crucible the values of I turned out to be half the values registered when the beam passes near the surface of the melt. After the first mechanical stirring, the difference of intensities decreased to 20%, and after the second stirring it disappeared completely. However, at further heating at the rate of 50 K/h the values of the passing beam intensity

again turned out to be lower than the corresponding values obtained at subsequent heating of the homogeneous melt and only after the temperature was raised to 920 K they coincided with them (Fig. 9).

Evidently, mechanical stirring of a microheterogeneous melt can contribute to the increase of its macroscopic homogeneity along the height, but does not remove its microheterogeneity. The inhomogeneity of the melt along its height is restored after stirring as a result of the sedimentation of disperse particles, and can be irreversibly removed only after homogenizing the system by its overheating above T_h .

Conclusions

Thus, in this work distinct dependencies of ultrasound velocity and γ -ray attenuation on the vertical coordinate were revealed in monophasic domain of Ga–Bi melts, which exist for at least several hours and are preserved at overheating by 200–400 K above the cupola of segregation. It was determined that with the increase of temperature, the inhomogeneity of melts decreases and, starting from a certain temperature T_h it irreversibly disappears.

It has been shown that the stated inhomogeneity is connected with the metastable microheterogeneous state of the investigated melts. The authors suppose that microheterogeneity appears either at the melting of the initial components, or at cooling the samples below the cupola of segregation. In both cases, the microemulsion is irreversibly destroyed at heating the melt above T_h . The region of the existence of metastable microheterogeneity has been built in the phase diagram of Ga–Bi system. It has been shown that mechanical stirring of the microheterogeneous melt can contribute to the increase of its macroscopic homogeneity along the height, but does not remove its microheterogeneity.

References

1. Wignall GD, Egelstaff PA (1968) J Phys C 1:1088
2. Herwig F, Hoyer W (1995) Mater Sci Eng A 190:L5
3. Wilson JR (1965) Metall Rev 10(40):552
4. Brodova IG, Popel PS, Eskin GI (2002) Liquid metal processing: applications to aluminium alloys production. Taylor & Francis, London
5. Filippov V, Popel P (2007) J Non-Cryst Solids 235:3269
6. Khairulin RA, Stankus SV, Sorokin AL (2002) J Non-Cryst Solids 297:120